

Assembly Instructions

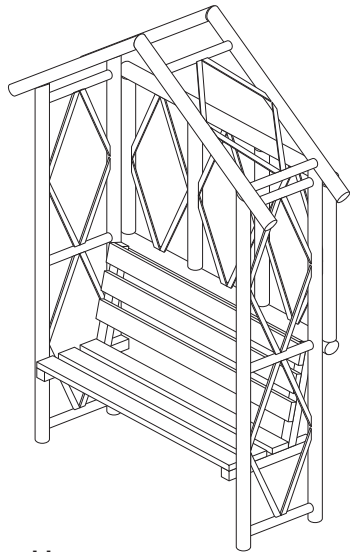

Before assembly

- We recommend that time is taken to read the instructions before starting assembly, then follow the easy step by step guide. The instruction sheet is only a guide to the assembly. Certain items may not be shown to scale.
- Check all components prior to assembly
- This product should be assembled by no less than two people.
- Never attempt to erect the assembly in high winds.
- It may be necessary to drill pilot holes for each screw.



Recommended tools for assembly

- Cross head screw driver
- Spirit level
- Step ladder

No.	Components	Qty.
1	Uprights	2
2	Seat	1
3	Seat back	1
4	Lattice back panel	1
5	Roof	2

No.	Fixing Kit	Qty.
6	100mm screws	22
7	50mm screws	16
8	L-brackets	4

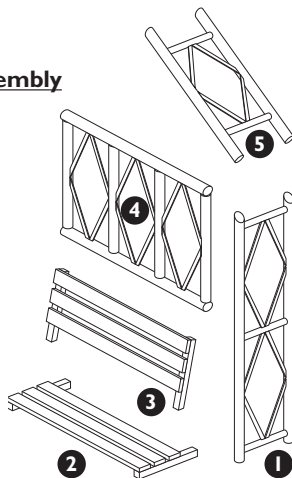

1. Seat

Position the seat between the uprights 350mm from the bottom of the upright. Ensure the angled ends of the uprights are correctly orientated and that the ends of the seat bearer at the back of the seat are level with the back of the uprights. Secure the seat in position using 1 x 100mm screw at each corner, screw through the seat bearer into the legs of the uprights. Add an L-bracket at each corner using 4 x 50mm screws per bracket.

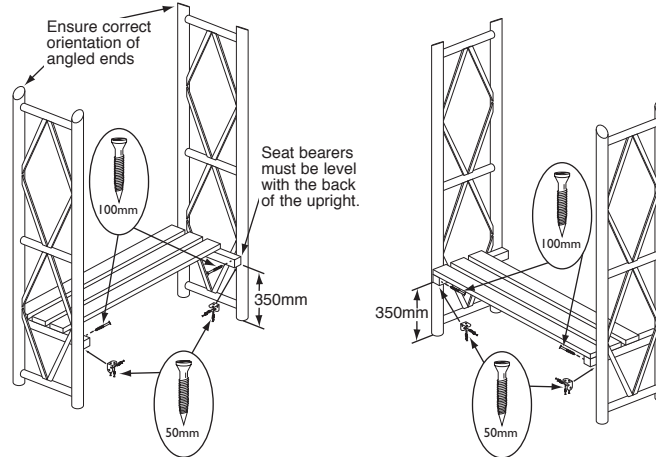

2. Seat back

Sit the seat back on top the of the seat bearers as shown below. Secure at each end using 1 x 100mm screw, screwed through the seat back bearer into the leg of the upright and 1 x 100mm screw, screwed up through each seat bearer into the end of the seat back bearer.

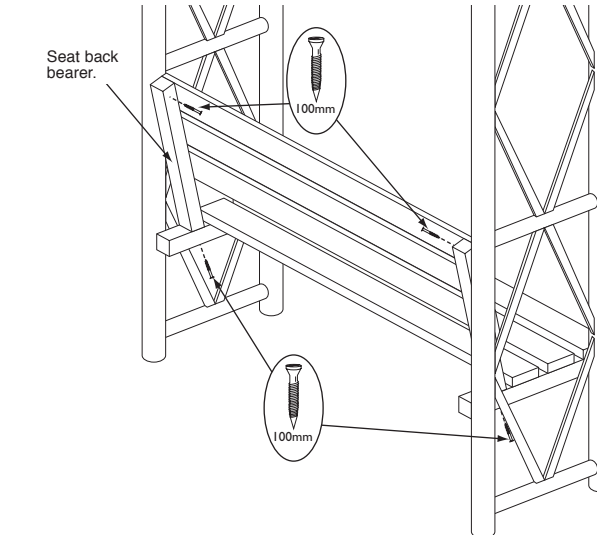

3. Back lattice panel

Position the back lattice panel just above the seat back. Secure to the back uprights using 4 x 100mm as shown below.

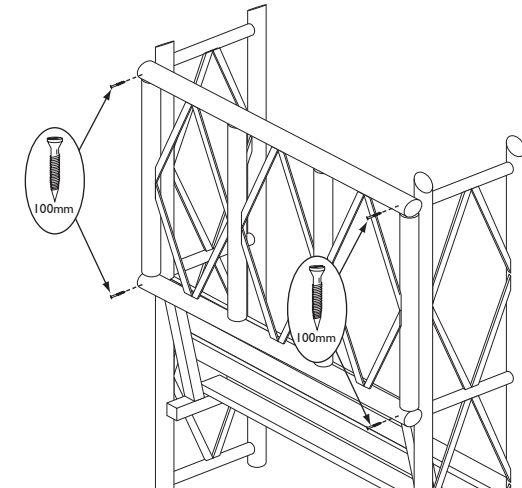

4. Roof

Secure the 2 roof sections together using 2 x 100mm screws as shown below. Attach the roof section to the uprights using 4 x 100mm screws. Secure through the pre-drilled holes into the angled ends of the uprights.

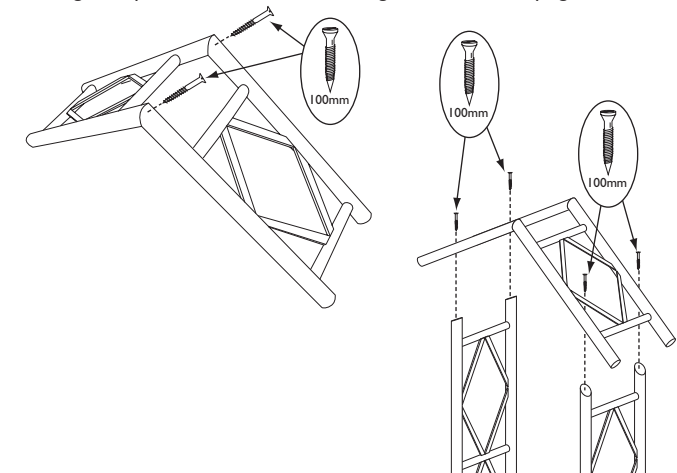

We constantly improve the quality of our products, occasionally the components may differ from the components shown and are only correct at time of printing. We reserve the right to change the specification of our products without prior notice.